

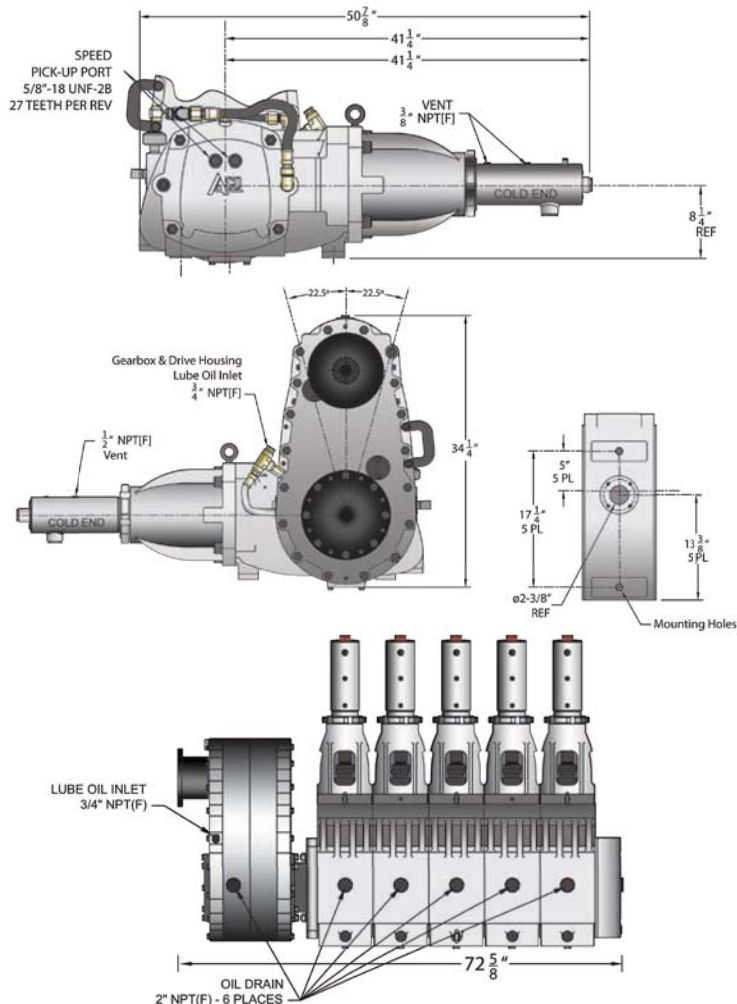

SLS

Features & Benefits

- Improved drive end design allows for longer life and cooler temperatures during operation
- Multiple configurations enable adaptability and conformity to mobile and/or stationary applications using a standard base model
- Better than 30 to 1 turndown ratios allows for a wide range of operating parameters, including low enough flows to meet coil-tubing applications
- Non Key Polygon Design (3-SLS) reduces drive end failure risk due to shaft key



5-SLS

High Temperature Nitrogen

Delicate operations such as furnace bake-outs, catalyst regeneration and hydrocarbon and solvent stripping have been safely performed using high temperature inert nitrogen as the controllable medium.

Leak testing

The safety and environmental integrity of oil and gas processing and refining facilities can be verified through the use of nitrogen, with a trace of Helium, at final commissioning. Some service companies claim to be able to accurately detect leaks of 0.10 SCF/year.

SLS Warm Ends



3-SLS

- counter balance optional
- left or right hand
- diverted cooling

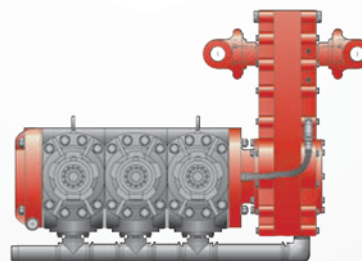

3-SLSGRO

- counter balance optional
- gear reduction
- external oil pump
- diverted cooling

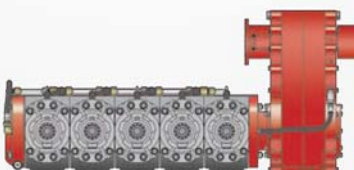

5-SLSGRO

- counter balance optional
- gear reduction
- external oil pump
- diverted cooling
- digital tachometer



ACD's high flow/pressure nitrogen pumps are used for pipeline and process applications, onshore and offshore, in the oil, gas and petrochemical industries.

Pump Model	Piston Dia In. (mm)	Pump RPM										
		MAWP	100	200	300	400	500	600	700	800	900	1000
		PSI / BAR	GPM / LPM	GPM / LPM	GPM / LPM	GPM / LPM	GPM / LPM	GPM / LPM	GPM / LPM	GPM / LPM	GPM / LPM	GPM / LPM
3-SLS	2.00 (50.8)	18,000 (1241)	7.80 (29.53)	15.61 (59.07)	23.41 (88.60)	31.21 (118.14)	39.01 (147.67)	46.82 (177.21)	54.62 (206.74)	62.42 (236.27)	70.23 (265.81)	78.03 (295.34)
5-SLS	2.00 (50.8)	18,000 (1241)	13.00 (49.22)	26.01 (98.45)	39.01 (147.67)	52.02 (196.90)	65.02 (246.12)	78.03 (295.34)	91.03 (344.57)	104.04 (393.79)	117.04 (443.01)	130.05 (492.24)
3-SLS	2.52 (64)	11,600 (800)	12.39 (46.89)	24.78 (93.78)	37.16 (140.67)	49.55 (187.55)	61.94 (234.44)	74.33 (281.33)	86.72 (328.22)	99.10 (375.11)	111.49 (422.00)	123.88 (468.89)
5-SLS	2.52 (64)	11,600 (800)	20.65 (78.15)	41.29 (156.30)	61.94 (234.44)	82.59 (312.59)	103.23 (390.74)	123.88 (468.89)	144.53 (547.03)	165.17 (625.18)	185.82 (703.33)	206.47 (781.48)
3-SLS	2.70 (68.5)	10,000 (689)	14.22 (53.83)	28.44 (107.65)	42.66 (161.48)	56.88 (215.30)	71.10 (269.13)	85.33 (322.96)	99.55 (376.78)	113.77 (430.61)	127.99 (484.44)	142.21 (538.26)
5-SLS	2.70 (68.5)	10,000 (689)	23.70 (89.71)	47.40 (179.42)	71.10 (269.13)	94.81 (358.84)	118.51 (448.55)	142.21 (538.26)	165.91 (627.97)	189.61 (717.68)	213.31 (807.39)	237.02 (897.10)
3-SLS	2.875 (73)	9,000 (620)	16.12 (61.03)	32.25 (122.06)	48.37 (183.09)	64.50 (244.12)	80.62 (305.15)	96.74 (366.18)	112.87 (427.21)	128.99 (488.24)	145.12 (549.27)	161.24 (610.30)
5-SLS	2.875 (73)	9,000 (620)	26.87 (101.72)	53.75 (203.43)	80.62 (305.15)	107.49 (406.87)	134.37 (508.58)	161.24 (610.30)	188.11 (712.01)	214.99 (813.73)	241.86* (915.45)	268.74* (1,017.16)
3-SLS	3.25 (82.5)	7000 (482)	20.60 (77.99)	41.21 (155.98)	61.81 (233.97)	82.42 (311.96)	103.02 (389.94)	123.63 (467.93)	144.23 (545.92)	164.84 (623.91)	185.44 (701.90)	206.05 (779.89)
5-SLS	3.25 (82.5)	7000 (482)	34.34 (129.98)	68.68 (259.96)	103.02 (389.94)	137.36 (519.93)	171.71 (649.91)	206.05 (779.89)	240.39 (909.87)	274.73 (1,039.85)	309.07 (1,169.83)	343.41 (1,299.82)
* Pressure limited by maximum Horsepower limit												
Brake HP @ MAWP	3-SLS	110	220	330	440	550	660	770	880	990	1100	
	5-SLS	184	369	553	738	922	1107	1291	1476	1500	1500	

Nitrogen Purging

Nitrogen purging using ACD pumps is a technique used to replace hydrocarbon vapors, flammable and toxic gases or air with an environmentally safe and inert dry atmosphere. The two most common methods of purging are displacement and dilution. The geometry of the process system determines which method is used. For simple systems, displacement purging is usually more effective in terms of time and cost, but for more complex systems, dilution purging is used.



3-SLS